

Nylite Spool & Shield

PRODUCT CODE: 969

Nylite spools are lighter than steel. High-performance (HP) spools are available for use with high-performance Class II ropes in sizes -1 through -5.

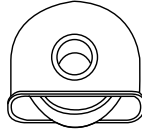

NYLITE SPOOL AND SHIELD

SIZE	DIAMETER inches	CIRCUMFERENCE inches	STANDARD SPOOL	HP SPOOL
			PART NUMBER	PART NUMBER
-1	3/8" – 1/2"	1-1/8" – 1-1/2"	969-0320	969-0321
-2	9/16" – 5/8"	1-3/4" – 2"	969-0400	969-0401
-3	3/4" – 13/16"	2-1/4" – 2-1/2"	969-0520	969-0521
-4	7/8" – 1-1/16"	2-3/4" – 3-1/4"	969-0680	969-0681
-5	1-1/8" – 1-5/16"	3-1/2" – 4"	969-0840	969-0841



Nylite Spool
(sizes -1 to -9)



HP Aluminum Spool
(sizes -1 to -5)

Nylite Shackle

PRODUCT CODE: 961

Easily installed into or removed from premade soft eyes, the Nylite Shackle takes advantage of the high-strength Nylite connector and synthetic rope. Connectors will not deform or rupture from repeated loadings.

The shackle working load limit (WLL) is stamped on each shackle.



-1 and -2 shackles are Electrolytic Zinc coated per ASTM B633-07 SC2 Type III. Sizes -3 through -9 shackles are hot-dip galvanized per ASTM A123.

SIZE	PART NUMBER	SHACKLE COATING	FITS ROPE DIAMETER inches	FITS ROPE CIRCUMFERENCE inches	WEIGHT EACH pounds
-1	961-032	Zinc Plated	3/8" – 1/2"	2" – 2-1/4"	0.4 lb
-2	961-040	Zinc Plated	9/16" – 5/8"	2-3/4" – 3"	0.8 lb
-3	961-052	Galvanized	3/4" – 13/16"	3-1/2" – 3-3/4"	1.3 lb
-4	961-068	Galvanized	7/8" – 1-1/16"	4-1/8" – 4-1/2"	3.0 lb
-5	961-084	Galvanized	1-1/8" – 1-5/16"	5" – 5-1/2"	4.8 lb
-6	961-112	Galvanized	1-1/2" – 1-3/4"	5-5/8" – 6"	16 lb
-7	961-144	Galvanized	2" – 2-1/4"	6-1/2" – 7"	19 lb
-8	961-168	Galvanized	2-1/2" – 2-5/8"	7-1/8" – 7-1/2"	30 lb
-9	961-208	Galvanized	2-3/4" – 3-1/4"	8-1/2" – 9"	48 lb

Nylite Snatch Block

PRODUCT CODE: 915

The Nylite Snatch Block maximizes a two-part lifting system without over stressing synthetic rope. The exclusive high-strength sheave reduces weight while providing the proper radius and groove shape to eliminate rope wear. The swivel plate has a locking bolt that makes change over easy and fast. The hook swivels under no- or low-load conditions.

Overall length (A) is 23"; hook opening with latch (B) is 1.5".

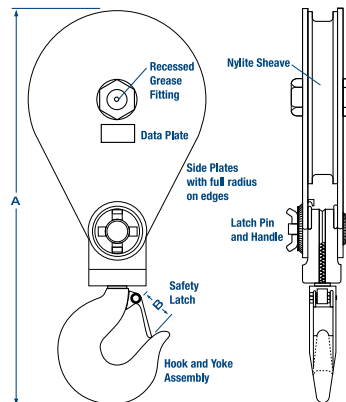

PART NUMBER	DIAMETER inches	WORKING LOAD TONS*	WEIGHT EACH pounds
9153210	7/8" – 1-1/8"	8 tons	33 lb

*Nylite Assemblies have working loads listed in tons. All working load values are based on a 4:1 safety factor.



2090 Thornton Street, Ferndale, WA 98248 USA
Tel 01.360.384.4669 | Fax 01.360.384.0572
www.SamsonRope.com